

Instruction manual
Manual de
Instrucciones
Manuel d'instructions

ESPAÑOL: PÁGINA 9
FRANÇAIS: PAGE 17

Gravity Feed Paint Spray Gun

**Pistola para Pintar por Rociado,
Alimentada por Gravedad**

**Pistolet à peinture à
alimentation par gravité**



MODEL PSH3
MODELO PSH3
MODÈLE PSH3

To learn more about Porter-Cable visit
our website at:
<http://www.porter-cable.com>

Pour de plus amples renseignements
concernant Porter-Cable, consultez
notre site Web à l'adresse suivante:
<http://www.porter-cable.com>

Para obtener más información sobre
Porter-Cable, visite nuestro sitio web en:
<http://www.porter-cable.com>

PORTER-CABLE®

IMPORTANT

Please make certain that the person who is
to use this equipment carefully reads and
understands these instructions before starting
operations.

IMPORTANTE

Asegúrese de que la persona que va a usar
esta herramienta lea cuidadosamente y
comprenda estas instrucciones antes de
empezar a operarla.

IMPORTANT

Veillez vous assurer que la personne qui
utilise cet outil lit attentivement et comprend
ces instructions avant de commencer à utiliser
l'outil.

SAFETY GUIDELINES - DEFINITIONS

This manual contains information that is important for you to know and understand. This information relates to protecting YOUR SAFETY and PREVENTING EQUIPMENT PROBLEMS. To help you recognize this information, we use the symbols below. Please read the manual and pay attention to these sections.

⚠ DANGER

indicates an imminently hazardous situation which, if not avoided, will result in death or serious injury.

⚠ WARNING

indicates a potentially hazardous situation which, if not avoided, could result in death or serious injury.

⚠ CAUTION

indicates a potentially hazardous situation which, if not avoided, may result in minor or moderate injury

CAUTION

used without the safety alert symbol indicates potentially hazardous situation which, if not avoided, may result in property damage.

IMPORTANT SAFETY INSTRUCTIONS

• SAVE THESE INSTRUCTIONS •



⚠ WARNING

IMPROPER OPERATION OR MAINTENANCE OF THIS PRODUCT COULD RESULT IN SERIOUS INJURY AND PROPERTY DAMAGE. READ AND UNDERSTAND ALL WARNINGS AND OPERATING INSTRUCTIONS BEFORE USING THIS EQUIPMENT.



⚠ WARNING

The Following Hazards Can Occur During The Normal Use Of This Product:

HAZARD	
Risk of explosion or fire - flammable materials	
WHAT COULD HAPPEN	HOW TO PREVENT IT
When paints or materials are sprayed, they are broken into very small particles and mixed with air. This will cause certain paints and materials to become extremely flammable and could result in serious injury or death.	Never spray near open flames or pilot lights in stoves or heaters. Never smoke while spraying. Provide ample ventilation when spraying indoors.
HAZARD	
Risk of explosion - incompatible materials	
WHAT COULD HAPPEN	HOW TO PREVENT IT
The solvents 1,1,1-Trichloroethane and Methylene Chloride can chemically react with the aluminum used in most spray equipment, and this gun and cup, to produce an explosion hazard and could result in serious injury or death.	Read the label or data sheet for the material you intend to spray. 1. Never use any type of spray coating material containing these solvents. 2. Never use these solvents for equipment cleaning or flushing. 3. If in doubt as to whether a material is compatible, contact your material supplier.
HAZARD	
Risk of breathing	
WHAT COULD HAPPEN	HOW TO PREVENT IT
Some paints, coatings and solvents may cause lung damage, and burns if inhaled or allowed to come into contact with skin or eyes.	Use a NIOSH approved mask or respirator and protective clothing designed for use with your specific application and spray materials. Some masks provide only limited protection against toxic materials and harmful paint solvent. Consult with a Safety Expert or Industrial Hygienist if uncertain about your equipment or materials.

HAZARD	
Risk of flying objects 	
WHAT COULD HAPPEN	HOW TO PREVENT IT
Certain parts are under pressure whenever the gun is connected to a pressurized air line. These parts may be propelled if the gun is disassembled.	Disconnect the gun from the air line, or completely depressurize the air line whenever the gun is to be disassembled.
Compressed air may propel dirt, metal shavings, etc. and possibly cause an injury.	Never point any nozzle or sprayer toward a person or part of the body. Always wear ANSI 278.1 safety approved goggles or glasses when spraying.
Prolonged exposure to air spray can result in permanent damage to hearing.	Always wear hearing protection when operating spray equipment.

HAZARD	
Risk of injection 	
WHAT COULD HAPPEN	HOW TO PREVENT IT
Spray guns operate at pressures and velocities high enough to penetrate human and animal flesh, which could result in amputation or other serious injury. ! See a physician immediately!	Never place hands in front of nozzle. Direct spray away from self and others.

SPECIFICATIONS

Air Inlet	1/4 NPS
Maximum Air Pressure	100 psi.
Recommended Operating Air Pressure	60 psi.
Cup	20 oz (600 cc)
Air Consumption @ 40 PSI	9.6 SCFM

GENERAL INFORMATION

⚠ CAUTION Before disassembly or removal of any part of gun or attached components, shut off compressor, release pressure by depressing trigger, and disconnect power source.
NEVER assume system pressure is zero!

⚠ WARNING TO AVOID CREATING AN EXPLOSIVE ATMOSPHERE, WORK ONLY IN WELL VENTILATED AREAS.

⚠ WARNING USE OF A FACE MASK IS RECOMMENDED TO PREVENT HINHALATION OF TOXIC MATERIAL.

OPERATION

⚠ WARNING DO NOT ATTEMPT TO UNCLOG (BACK FLUSH) SPRAY GUN BY SQUEEZING TRIGGER WHILE HOLDING FINGER IN FRONT OF FLUID NOZZLE.

⚠ CAUTION Pressure may vary according to viscosity of material used. Maximum working pressure of gun is 100 psi. DO NOT EXCEED PRESSURE LIMIT OF GUN OR ANY OTHER COMPONENT IN SYSTEM!

⚠ CAUTION Prior to daily operation, make certain that all connections and fittings are secure. Check hose and all connections for a weak or worn condition that could render system unsafe. All replacement components such as hose or fittings must have a working pressure equal to or greater than system pressure.

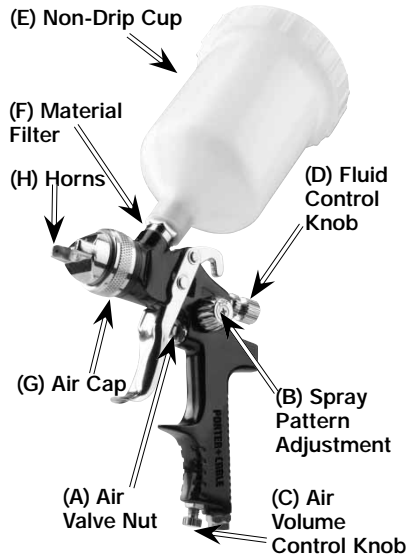

Prior to shipment, this gun was treated with an anticorrosive agent. Before using this gun make sure that it is carefully flushed with thinner.

1. The position of the air cap (H) horns will determine the spray pattern. Loosen (G) air cap and rotate horns to achieve desired pattern. Tighten air cap.
2. Attach material cup to the gun. NOTE: The (F) material filter supplied is optional to protect against contaminants and small particles. See parts list for material filter orientation.
3. Attach air supply line to 1/4 NPS air inlet.

⚠ CAUTION NEVER point spray gun at self or any other person. Accidental discharge of material may result in serious injury.

4. Adjust air pressure at air compressor.

⚠ CAUTION DO NOT exceed 100 psi.

5. Depress spray gun trigger fully to spray material. NOTE: Depressing trigger partially will cause only air to be released.

Adjust spray gun:

- a. Amount of material released (density of "fan spray") is controlled by (D) fluid control knob. Turn knob counterclockwise to increase, or clockwise to decrease, the fluid flow.
- b. Width of "fan spray" is governed by (B) pattern adjustment knob. Turn knob counterclockwise to increase, or clockwise to decrease, air flow.
- c. Air quantity is controlled by (C) air-volume control knob. Turn knob counterclockwise to increase, or clockwise to decrease, the air flow.

NOTE: Care should be exercised when handling spray gun to avoid damage to the orifice of the air cap and tip of fluid nozzle. Damage to these parts results in irregular spray patterns.

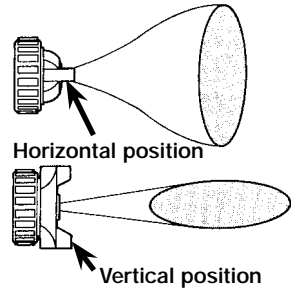

MAINTENANCE

▲ CAUTION Always exercise extreme care when using any solvent or thinner. Never clean gun near fire, flame, or any source of heat or sparks. Properly dispose of used cleaning materials.

▲ CAUTION DO NOT soak entire spray gun in solvent or thinner for a long period of time as this will destroy lubricants and possibly make motion uneven. NEVER use lye or caustic alkaline solution for cleaning. Such solutions will attack aluminum alloy parts of gun.

It is important that spray gun be cleaned after daily use. Cleaning is accomplished by spraying appropriate solvent or thinner through system. Wipe exterior of spray gun with solvent soaked cloth or use cleaning brush(s) provided to remove any accumulated material.

Cleaning

- (a) Empty material from gravity feed cup and replace with a suitable solvent.
- (b) Operate trigger until all material traces have disappeared and gun is thoroughly clean.
- (c) Clean air cap with brush.

IMPORTANT: Make certain air cap and fluid nozzle are kept clean at all times. If necessary, remove these two components and soak them in solvent. DO NOT use hard objects to clean clogged holes. The smallest amount of damage may cause irregular spray pattern.

NOTE: If fluid nozzle is to be removed for thorough cleaning, squeeze trigger to prevent damage of fluid needle tip when unscrewing nozzle.

Lubrication

Lubrication procedures must be observed after thoroughly cleaning the gun to ensure effective, high quality performance of spray gun.

1. Lubricate working points with straight mineral oil, or castor oil.
2. Periodically, place a few drops of oil on tapered sections of fluid nozzle to ensure easy operation of air cap. When spraying water base materials, coat fluid nozzle inside and outside with straight mineral oil after each use.
3. Outer diameter of needle sleeve of fluid needle assembly must be lubricated occasionally with straight mineral oil.

Change or Replace nozzle set

When changing nozzle set, make sure the complete nozzle set is exchanged. A set includes an air cap, fluid nozzle, and fluid needle. **NOTE:** Assemble fluid nozzle before putting in fluid needle.

Nozzle Sets

Part Number	Orifice Diameter	Material
*D26403	1.4 mm (.055")	high solids, multipurpose
D26404	1.7 mm (.067")	primers
D26405	2.0 mm (.079")	latex, acrylics, enamels







* Standard size is supplied with gun. Other nozzle sets should be ordered separately. A set includes an air cap, fluid nozzle, and fluid needle.

Exchange of the self-tensioning needle packing

The fluid needle seal is effected by a Teflon packing with self-tensioning compression spring. To change the packing during general overhaul, please use the socket spanner provided.

TROUBLESHOOTING

NOTICE: See parts list to identify parts referred to in these Troubleshooting steps.

Defective Pattern	Likely Cause	Suggested Remedy
<p>A.</p> 	<p>Dried material is clogging side-port "A" and causing side-port "B" to blow spray towards the clogged side</p> 	<p>Soak side-ports in thinner to clean clog. DO NOT poke any opening with hard objects.</p>
<p>B.</p> 	<p>Dried material at fluid nozzle "C" restricts air flow</p> <p>Loose air nozzle Air pressure set too high</p> 	<p>Remove air nozzle. Wipe off fluid tip using a cloth soaked in thinner or by soft brush</p> <p>Fasten nozzle securely Reduce air pressure</p>
<p>C. Spitting, irregular or fluttering spray</p> 	<p>Fluid nozzle cracked or worn Leak at thread of fluid nozzle Leak at fluid needle</p> <p>Needle packing worn out Insufficient fluid in cup Vent hole in container cover clogged</p>	<p>Tighten or replace Tighten fluid nozzle Tighten compression nut assembly or replace needle packing Replace packing Fill cup with fluid Clean Out</p>
<p>D. Split spray pattern</p> 	<p>Air pressure too high</p>	<p>Turn pattern control knob clockwise to decrease fan width. Turn fluid needle adjusting nut counterclockwise to increase fluid flow</p>
<p>E. Unatomized or spattered spray</p>	<p>Material too heavy</p> <p>Insufficient air pressure</p> <p>Fluid pressure too high Dried material on tip of fluid nozzle or air jets of air cap</p>	<p>Thin material or use larger orifice fluid nozzle set Increase pressure to within limit</p> <p>Reduce pressure Clean</p>
<p>F. Inadequate air delivery</p>	<p>Air needle partially closed Dried material in air jets or air cap Obstruction in air line</p>	<p>Open control knob Clean</p>
<p>G. Excessive fog</p>	<p>Air pressure too high for viscosity of fluid</p>	<p>Remove obstruction Reduce air pressure and/or open fluid control knob</p>
<p>H. Material leaking from fluid inlet of cup.</p>	<p>Loose cup or foreign substances on/between cup thread and fluid inlet</p>	<p>Tighten and clean or replace it</p>
<p>I. Material leaking from nozzle when trigger is released</p>	<p>Worn fluid needle Dried material in tip of nozzle Loose packing nut</p>	<p>Replace Clean Tighten needle packing nut by turning counterclockwise</p>

PARTS LIST

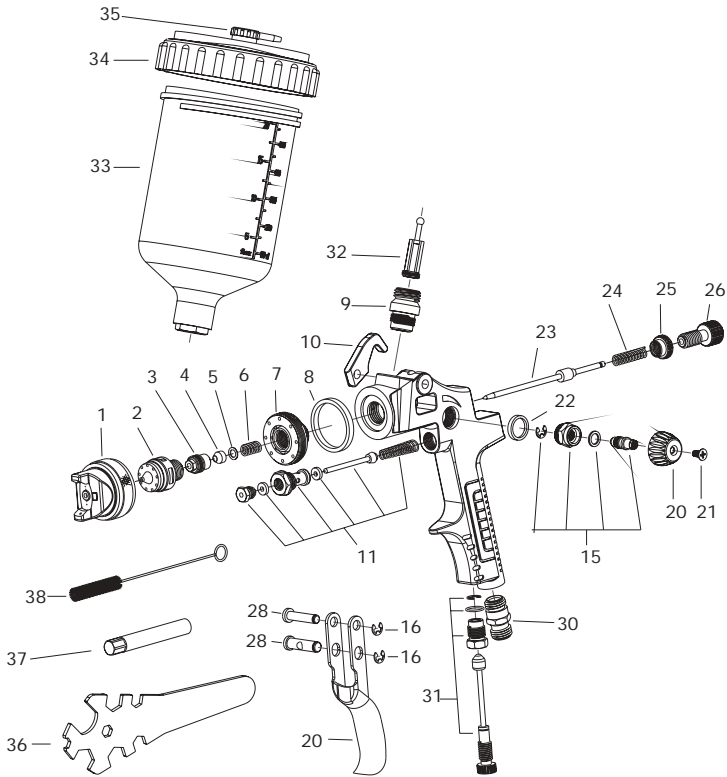

REF

<u>NO</u>	<u>DESCRIPTION</u>	<u>PART NO</u>
1	Air Nozzle with Cap	D25242
2	Fluid Nozzle	D25243
3	Packing Screw for Paint Needle	D25156
4	Teflon Seal	D25157
5	Washer	D25160
6	Spring	D25161
7	Brass Ring	D25162
8	Gasket	D25163
9	Connector for 0.6 Liter cup	D25164
10	Hanger	D25166
11	Air Valve Assembly	D25167
15	Spray Regulating Nut Assembly	D25171
16	E-Ring	D25172
20	Control Knob	D25177
21	Screw	not available
22	Gasket	D25248

REF

<u>NO</u>	<u>DESCRIPTION</u>	<u>PART NO</u>
23	Paint Needle Complete	D25245
24	Spring for Paint Needle	D25246
25	Lock to Fluid Control Knob	D25247
26	Fluid Control Knob	D25249
27	Trigger	D25182
28	Trigger Pin (no hole)	D25183
29	Trigger Pin (with hole)	D25184
30	Air Connector	D25252
31	Air Adjusting Valve Assembly	D25192
32	Material Filter	D25186
33	Plastic Cup	D25254
34	Cover	D25256
35	Non-drip Control Device	D25255
36	Spanner Wrench	D25189
37	Socket Spanner	D25190
38	Brush	D25191

LIMITED WARRANTY

PORTER-CABLE CORPORATION warrants to the original purchaser that all products covered under this warranty are free from defects in material and workmanship. Products covered under this warranty include air compressors, air tools, service parts, pressure washers, and generators, which have the following warranty periods:

- 3 YEARS - Limited warranty on 2-stage oil-free air compressor pumps that operate at 1725 RPM.
- 2 YEARS - Limited warranty on oil-lubricated air compressor pumps.
- 1 YEAR - Limited warranty on all other air compressor components.
- 2 YEARS - Limited warranty on electric generator alternators.
- 1 YEAR - Limited warranty on other generator components.
- 2 YEARS - Limited warranty on pneumatic air tools as described in Porter-Cable general catalog.
- 1 YEAR - Limited warranty on pressure washers used in consumer applications (i.e. personal residential household usage only).
- 90 DAY - Pressure washers used for commercial applications (income producing) and service parts.
- 1 YEAR - Limited warranty on all accessories.

Porter-Cable will repair or replace, at Porter-Cable's option, products or components which have failed within the warranty period. Service will be scheduled according to the normal work flow and business hours at the service center location, and the availability of replacement parts. All decisions of Porter-Cable Corporation with regard to this limited warranty shall be final.

This warranty gives you specific legal rights, and you may also have other rights which vary from state to state.

RESPONSIBILITY OF ORIGINAL PURCHASER (initial User):

- To process a warranty claim on this product, DO NOT return it to the retailer. The product must be evaluated by an Porter-Cable Authorized Warranty Service Center. For the location of the nearest Porter-Cable Authorized Warranty Service Center call 1-888-559-8550, 24 hours a day, 7 days a week.
- Retain original cash register sales receipt as proof of purchase for warranty work.
- Use reasonable care in the operation and maintenance of the product as described in the Owners Manual(s).
- Deliver or ship the product to the nearest Porter-Cable Authorized Warranty Service Center. Freight costs, if any, must be paid by the purchaser.
- Air compressors with 60 and 80 gallon tanks will be inspected at the site of installation. Contact the nearest Porter-Cable Authorized Warranty Service Center that provides on-site service calls, for service call arrangements.
- If the purchaser does not receive satisfactory results from the Porter-Cable Authorized Warranty Service Center, the purchaser should contact Porter-Cable.

THIS WARRANTY DOES NOT COVER:

- Merchandise sold as reconditioned, used as rental equipment, and floor or display models.
- Merchandise that has become damaged or inoperative because of ordinary wear, misuse*, cold, heat, rain, excessive humidity, freeze damage, use of improper chemicals, negligence, accident, failure to operate the product in accordance with the instructions provided in the Owners Manual(s) supplied with the product, improper maintenance, the use of accessories or attachments not recommended by Porter-Cable, or unauthorized repair or alterations.
 - * An air compressor that pumps air more than 50% during a one hour period is considered misuse because the air compressor is undersized for the required air demand.
- Repair and transportation costs of merchandise determined not to be defective.
- Costs associated with assembly, required oil, adjustments or other installation and start-up costs.
- Expendable parts or accessories supplied with the product which are expected to become inoperative or unusable after a reasonable period of use, including but not limited to sanding disks or pads, saw and shear blades, grinding stones, springs, chisels, nozzles, o-rings, air jets, washers and similar accessories.
- Merchandise sold by Porter-Cable which has been manufactured by and identified as the product of another company, such as gasoline engines. The product manufacturer's warranty, if any, will apply.
- **ANY INCIDENTAL, INDIRECT OR CONSEQUENTIAL LOSS, DAMAGE, OR EXPENSE THAT MAY RESULT FROM ANY DEFECT, FAILURE OR MALFUNCTION OF THE PRODUCT IS NOT COVERED BY THIS WARRANTY.** Some states do not allow the exclusion or limitation of incidental or consequential damages, so the above limitation or exclusion may not apply to you.
- **IMPLIED WARRANTIES, INCLUDING THOSE OF MERCHANTABILITY OR FITNESS FOR A PARTICULAR PURPOSE, ARE LIMITED TO ONE YEAR FROM THE DATE OF ORIGINAL PURCHASE.** Some states do not allow limitations on how long an implied warranty lasts, so the above limitations may not apply to you.

PORTER-CABLE®

Porter-Cable Corporation
Jackson, TN USA
1-888-559-8550